

ModuFLEX^{Basic}

General Information:

- Highest winding quality with the shortest web paths
- Suitable for almost all web-shaped materials
- Clear and concise construction
- Maintenance friendly
- Ergonomic and easy operation
- High flexibility and precision

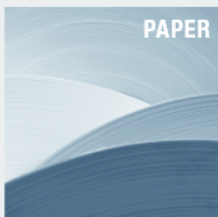

ModuFLEX^{Basic}

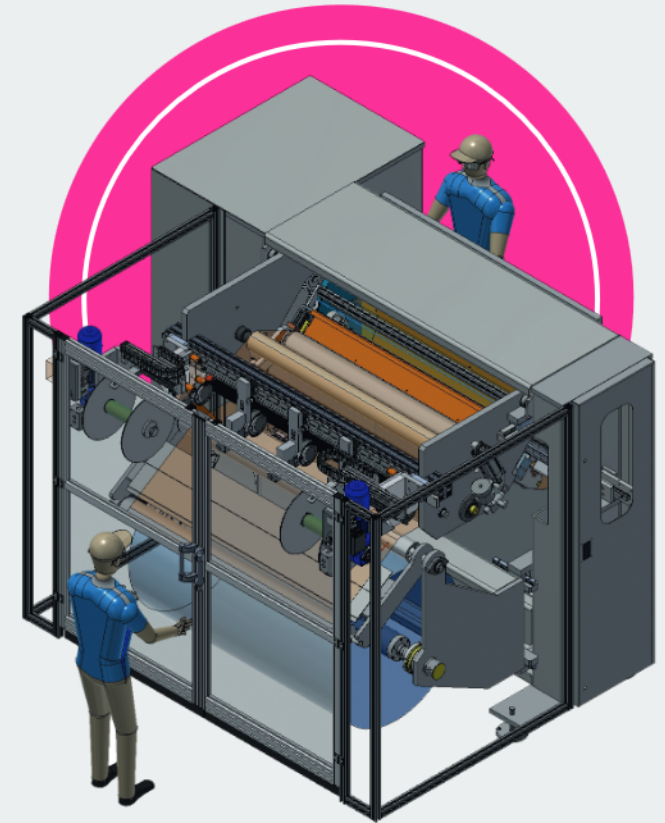

THE BÄUMER KNOW-HOW



Bäumer GmbH
converting machines

Hauernweg 5, 48496 Hopsten - Germany

Phone +49 5458 93661-0

E-Mail: vertrieb@b-ft.de

www.baeumer-converting-machines.de



Bäumer GmbH
converting machines

ModuFLEX Basic

Unwinder:

- Working width: max. 1600 mm
- Jumbo roll diameter: max. Ø 1000 mm
- Unwinder with pneumatic brake and winding shaft
- Autom. web edge control system

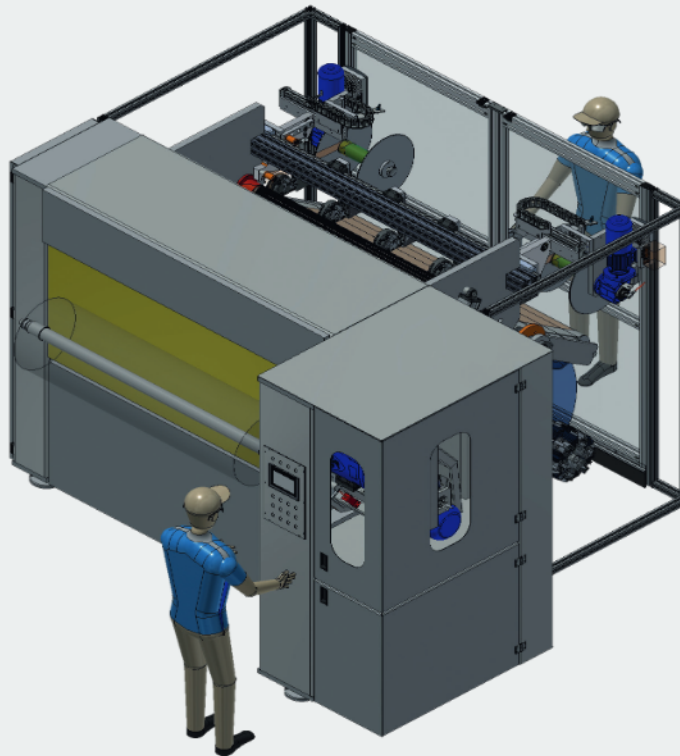
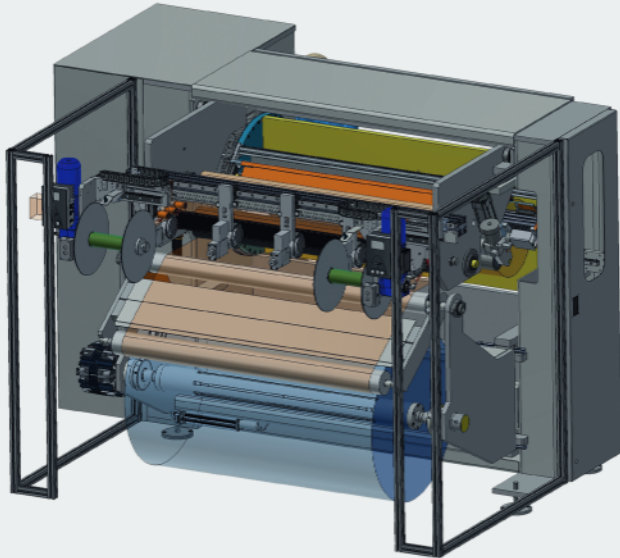

Rewinder:

- Double turret rewriter up to max. Ø 450 mm
- Fully automatic winding system with vacuum suction table and integrated Flexi-Lip
- Cross cutting as shear cut with driven circular blade
- Protection device between the winding positions
- Manual roll removal and core loading

Options:

- Vacuum splice-table for unwinder
- Infinitely manually adjustable slit (blade-, crush- or shear cut) with measuring scale
- Additional edge trim winder with coupled knives
- Complete sound absorption for highly adhesive materials
- Upgrade to ModuFLEX with automatic core feeding incl. core positioning and automatic roll unloading and roll end taping

